



Plattsburgh, New York

Scott Lawliss
Fire Chief

Plattsburgh Fire Department
65 Cornelia Street
Plattsburgh, NY 12901
Tel: 518-536-7542
Fax: 518-561-8236
lawliss@cityofplattsburgh-ny.gov

MEMO

TO: Mayor Colin L. Read
Members of the Common Council

FROM: Fire Chief, Scott Lawliss

DATE: May 7, 2019

RE: Fire and Ambulance Responses

For this week's period: Tuesday, April 30, 2019 to Monday, May 6, 2019
our Department has responded to the following:

Fire Calls	<u>17</u>
	4 EMS assist initiated patient care prior to transport ambulance
	7 alarm activation with investigation of cause
	1 overheated motor
	1 MVA with patient care and hazardous mitigation
	1 cooking fire
	2 excessive heat/scorch burns
	1 smoke/odor removal
Ambulance Calls	50
Mutual Aid by CVPH	15

Architectural & Engineering Design Associates, P.C.

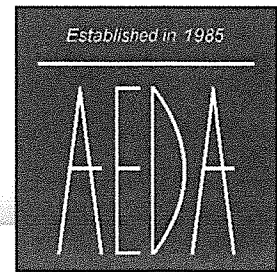

April 26, 2019

Mr. Matthew Miller
Director of Community Development
City of Plattsburgh
215 Idaho Avenue
Plattsburgh, NY 12901

RE: AEDA Design Proposal – GFNB Site Parking Lot - 2019

Dear Mr. Miller:

Architectural & Engineering Design Associates, P.C. (AEDA) is pleased to provide this proposal for engineering services for the proposal rebuild of the former Glens Falls National Bank site to a new City Parking Lot. Based on our meeting and review of the project, I can summarize the scope of the project as follows:

- City to provide demolition of existing structures, utilities and building on the site.
- City to provide all background documents for Oak/Division/Margaret Street roadways (i.e.- original design plans, utility plans/condition studies, soil reports, etc.)
- AEDA to provide complete replacement design plans for a new parking lot with approximately 100-125 parking spaces.

Based on the above information, AEDA offers the following design services:

Contract Design Services:

- Review of existing plans/documents.
- Field review/inspection existing conditions.
- Boundary survey, mapping and topography for the property.
- Recommendation for any further fieldwork, testing, etc. to be provided by the City to facilitate final engineering design.
- Site Plan(s) for Construction (planning, grading, utilities, stormwater/Sediment & Erosion Control, Lighting, Landscaping)
- Project technical specification for construction.
 - AIA Base Contract Documents
- Estimate of construction cost for proposed project
- Representation at two (2) City of Plattsburgh Planning Board meetings to obtain site plan approval.

Architectural & Engineering Design Associates, P.C. – 1246 Route 3, P.O. Box 762, Plattsburgh, NY 12901
Tel. 518.562.1800 Fax. 518.562.1702 Email jaa@aedapc.com Web www.aedapc.com

- Representation at one (1) Clinton County Planning Board meeting to obtain site plan approval.

AEDA proposes to provide architectural/engineering design services to complete all tasks/items outlined above for the lump sum fee of Twenty Five Thousand One Hundred Dollars (\$25,100.00).

Contract Bidding Services:

- Preparation of Advertisement to Bidders
- Schedule & Conduct one on-site meeting to review project prior to bid.
- Review comments & questions from contractors & issue necessary responses.
- Review all eligible bids and prepare recommendation of award to the owner.
- Review/Preparation of Contract, Notice of Award and Notice to Proceed for the selected contractor.

AEDA proposes to provide architectural & engineering contract bidding services to complete all tasks/items outlined above for the lump sum fee of Two Thousand Nine Hundred Dollars (\$2,900.00).

Contract Administrative Services:

- Schedule & Conduct one pre-construction meeting
- Weekly job meetings and periodic inspections of the project site (90-day construction time).
- Review of Contractor Submittals.
- Review of Monthly Payment applications.
- Prepare Change Orders and Construction Change Directives as necessary.
- Final inspection and preparation of "punch-list" items to be completed in order to issue a certificate of completed works.

AEDA proposes to provide architectural & engineering contract administrative services to complete all tasks/items outlined above for the lump sum fee of Six Thousand Six Hundred Dollars (\$6,600.00).

Note that our proposal specifically excludes any work associated with State/Federal approvals, environmental (Lead, asbestos & PCB's) or historical survey/inspection services, utility testing/inspection, geotechnical services, traffic studies, complete land surveying services and/or resident construction inspection. AEDA can provide any of these services should they become necessary either with our own staff or through other local consultants with whom we work regularly. In addition, the proposal also excludes all permit/review fees associated with the project. All such fees will be paid for directly by the Owner at the time of submission.

Attached please find the AEDA "standard form of agreement for professional services". If you find this proposal and agreement acceptable please sign and return one copy of the agreement with a retainer in the amount of \$1,000.00 and we can schedule the work.

Thank you for the opportunity to provide this proposal. Should you have any questions, please feel free to contact me.

Sincerely,

A handwritten signature in black ink, appearing to read "M. Coon". The signature is fluid and cursive, with a long horizontal stroke at the end.

Michael Coon, P.E.
Project Engineer

**STANDARD AGREEMENT for PROFESSIONAL SERVICES
(SHORT FORM)**

This is an Agreement made as of April 26, 2019 between City of Plattsburgh

of c/o – Matthew Miller, 41 City Hall Place, Plattsburgh, NY 12901 which is a Municipal Client (Hereinafter called the CLIENT), and Architectural & Engineering Design Associates P.C., 1246 State Rt. 3, P.O. Box 762, Plattsburgh, NY 12901, which is a professional corporation registered in the State of New York (hereinafter called AEDA.)

A. CLIENT and AEDA, for the mutual consideration hereinafter set forth, agree as follows: See attached proposal letter dated April 26, 2019

B. CLIENT agrees to pay AEDA as compensation for services as follows: See attached proposal letter dated April 26, 2019

Any additional services requested and/or expenses “excluded” shall be billed for against the AEDA Fee Schedule attached to the agreement.

C. CLIENT agrees to pay AEDA a retainer with this Agreement of \$1,000.00

Fees and other charges will be invoiced monthly. The amount of each invoice shall be due at the time of billing. When bills are not paid within 30 days, a late payment service charge will be charged on any unpaid balance at the rate of 1.5% compounded monthly (annual rate of 18%) or the highest rate allowable under applicable State Law, whichever is higher.

D. CLIENT shall furnish the following: Any existing plans available for the building/site, property survey and mapping.

E. This Agreement includes the Standard Terms and Conditions shown below and on the back of this document and are incorporated herein by this reference.

F. The person signing this Agreement warrants he/she has authority to sign as, or on behalf of, the CLIENT. If such person does not have such authority, it is agreed that he/she will be personally liable for all breaches of this Agreement, and that in any action against them for breach of such warranty, a reasonable attorney’s fee shall be included in any judgment rendered.

AGREED TO:

(Client’s Name)

BY:

(Authorized Signature/Date)

TITLE: _____

(Authorized Signature/Date)

TITLE: _____

AGREED TO:

Architectural & Engineering Design Assoc. PC

BY: Andrew C. Abdallah

(Authorized Signature/Date)

TITLE: President

STANDARD TERMS & CONDITIONS OF AGREEMENT

1. **EXTRA WORK:** Extra work shall include, but not be limited to, additional office or field work caused by policy or procedural changes of governmental agencies, changes in the project, and work necessitated by any of the causes described in Paragraph 5 hereof.
2. **OWNERSHIP OF DOCUMENTS:** All tracings, specifications, computations, survey notes and other original documents as instruments of service are and shall remain the property of AEDA unless otherwise provided by law. CLIENT shall not use such items on other projects without AEDA’S prior written consent. AEDA shall not release CLIENT’S data without authorization.
3. **LIMITATIONS OF COST ESTIMATES:** Any estimate of the cost of the project services or any part thereof is not to be construed, nor is it intended, as a guarantee of the total cost.
4. **APPROVAL OF WORK:** The work performed by AEDA shall be deemed approved and accepted by CLIENT as and when invoiced unless CLIENT objects within 15 days of the invoice date by written notice specifically stating the details in which CLIENT believes such work is incomplete or defective.
5. **DELAY:** Any delay, default or termination in or of the performance of any obligations of AEDA under this Agreement caused directly or indirectly by strikes, accidents, acts of God, shortage or unavailability of labor, materials, power or transportation through normal commercial channels, failure of CLIENT or CLIENT’S agents to furnish information or to approve or disapprove AEDA’S work promptly, late, slow or faulty performance by CLIENT, other contractors or governmental agencies, the performance of whose work is precedent to or concurrent with the performance of AEDA’S

work, or any others acts of the CLIENT'S or any other Federal, State or local government agency, or any other cause beyond AEDA'S reasonable control, shall not be deemed a breach of this Agreement. The occurrence of any such event shall suspend the obligations of AEDA as long as performance is delayed or prevented thereby, and the fees due hereunder shall be equitably adjusted.

6. **TERMINATION:** The obligation to provide further services under this Agreement may be terminated by either party upon seven (7) days written notice in the event of substantial failure by the other party to perform in accordance with the terms hereof through no fault of the terminating party. In the event of any termination, AEDA shall be paid for all services rendered to the date of termination as well as for all reimbursable expenses and termination expenses. For purposes of this section, the failure of the CLIENT to pay AEDA within thirty (30) days of receipt of an invoices shall be considered such a substantial failure. In the event of a substantial failure on the part of the CLIENT, AEDA in addition to the right to terminate set forth in the paragraph, may also elect to suspend work until the default in question has been cured. No delay or omission on the part of AEDA in exercising any right or remedy hereunder shall constitute a waiver of any such right or remedy on any future occasion.
7. **INDEMNIFICATION:** CLIENT shall indemnify, defend and hold AEDA harmless for any and all loss, cost, expense, claim, damage, or liability, of any nature arising from (a) soil conditions; (b) changes in plans or specifications made by CLIENT or others; (c) use by CLIENT or others of plans, surveys, or drawings unsigned by AEDA or for any purpose other than the specific purpose for which they were designed; (d) job site conditions and performance of work on the project by others; (e) inaccuracy of data or information supplied by CLIENT; and (f) work performed on material or data supplied by others, unless said loss was solely caused by AEDA'S own negligence.
8. **LITIGATION:** Should litigation be necessary to collect any portion of the amounts payable hereunder, then all costs and expenses of litigation and collection, including without limitation, fees, court costs, and attorney's fees (including such costs and fees on appeal), shall be the obligation of the CLIENT.
9. **REPLACEMENT OF SURVEY STAKES;** AEDA, if included in Paragraph A of the Agreement, will provide necessary construction stakes. In instances where it is determined that negligence on the part of the CLIENT or others results in the need for restaking, the cost of such restaking will be billed as an extra to the CLIENT on a time and material basis. It will be the CLIENT'S responsibility to provide adequate protection of the stakes against their own negligence of those working for or with them and against vandalism by others. If staking is ordered by the CLIENT or others prematurely and construction does not take place, it will also be the CLIENT'S responsibility to protect said stakes until such time as construction takes place..
10. **OBSERVATION AND TESTING OF CONSTRUCTION, SAFETY:** The observation and testing of construction is not included herein unless specifically agreed upon in the Scope of Services as set forth in Paragraph A of this Agreement. It should be understood that the presence of AEDA'S field representative will be for the purpose of providing observation and field testing. Under no circumstances is it AEDA'S intent to directly control or supervise the physical activities of the contractor's workmen to accomplish the work on this project. The presence of AEDA'S field representative as the site is to provide the CLIENT with a continuing source of information based upon the field representative's observations of the contractor's work, but does not include any superintending, supervision, or direction of the actual work of the contractor or the contractor's workmen. The contractor should be informed that neither the presence of AEDA'S field representative nor observation and testing personnel shall excuse the contractor in any way for effects discovered in their work. It is understood that AEDA will not be responsible for job or site safety on the project.
11. **RESTRICTIONS ON USE OF REPORTS:** It shall be understood that any reports rendered under this Agreement will be prepared in accordance with the agreed Scope of Services and pertain only to the subject project and are prepared for the exclusive use of the CLIENT. Use of the reports and data contained therein for other purposes is at the CLIENT'S sole risk and responsibility.
12. **LIMITATIONS OF CONSULTANT'S LIABILITY:** The CLIENT agrees to limit AEDA'S liability to the CLIENT and to all Construction Contractors and Subcontractors on the Project, due to AEDA'S professional negligent acts, errors or omission, such that the total aggregate liability of AEDA to those named shall not exceed fifty thousand dollars (\$50,000.00) or 50% of AEDA'S total fee for services rendered on this Project, whichever is the greater.
13. **CONTROLLING LAWS:** The Agreement is to be governed by the Laws of the State of New York.
14. **INSURANCE:** AEDA shall procure and maintain throughout the period of this Agreement, at AEDA'S own cost, insurance for protection from claims under worker's compensation, temporary disability and other similar insurance required by applicable State and Federal Laws. Certificates for all such policies of insurance shall be provided to the CLIENT upon written request. AEDA shall not be responsible for any loss, damage or liability beyond the amount, limits and conditions of such insurance.
15. **SUCCESSORS AND ASSIGNS:** Neither CLIENT nor AEDA shall assign, sublet or transfer any rights under or interest in (including, but without limitation, moneys that may become due or moneys that are due) this Agreement without the written consent of the other, except to the extent that any assignment, subletting or transfer is mandated by law or the effect of this limitation may be restricted by law.
16. **ARBITRATION:** All claims, counterclaims, disputes and other matters in question between the parts hereto arising out of or relating to this Agreement or breach thereof may, at the option of AEDA be decided by arbitration in accordance with the Construction Industry Arbitration Rules of the American Arbitration Association. Any such arbitration shall take place in the Town of Plattsburgh, Clinton County, New York
17. **NOTICES:** All notices called for by this Contract shall be in writing and shall be deemed to have been sufficiently given or served when presented personally and when deposited in the mail, postage prepaid, certified and return receipt requested, addressed as stated in the Agreement.
18. **RIGHT OF ENTRY:** The CLIENT will provide right of entry for our staff, subcontractors and all necessary equipment in order to complete the work. AEDA will take all reasonable precautions to minimize damage to the property. It is understood by CLIENT that in the normal course of work some damage may occur, the correction of which is not part of this Agreement.
19. **UTILITIES:** In the prosecution of our work, AEDA will take all reasonable precautions to avoid damage or injury to subterranean structures or utilities. Client agrees to hold AEDA harmless for any damages to subterranean structures and utilities.
20. **STANDARD OF CARE:** Services performed by AEDA under this Agreement will be conducted in a manner with the level of care and skill ordinarily exercised by members of the professions currently practicing under similar conditions. No other warranty, express or implied is made.

21. RENOVATION/REHABILITATION OF EXISTING BUILDINGS: Where the work involves remodeling and /or rehabilitation of an existing building, CLIENT agrees that certain assumptions must be made regarding existing conditions, and because some of these assumptions may not be verifiable without expending additional sums of money, or destroying otherwise adequate or serviceable portions of the structure, CLIENT agrees that, except for negligence on the part of AEDA, CLIENT will hold harmless, indemnify and defend AEDA from and against any and all claims arising out of the professional services provided under this Agreement.
22. EMPLOYEE RETENTION: CLIENT agrees not to hire or solicit for employment, for themselves or others, the ENGINEER'S employee during the term of this agreement and for a period of one year thereafter.
23. ASBESTOS AND HAZARDOUS WASTE: Where the work involves asbestos and /or hazardous wastes, CLIENT agrees that the handling or removal of asbestos, asbestos products and hazardous wastes involves certain health risks which require specific safety measures. AEDA will not be responsible for safety and safety measures on the job, including measures for the protection of employees, contractors, subcontractors and / or the general public. Such responsibility for safety measures is and shall remain that of the contractor. CLIENT agrees that, except for claims and damages arising from negligent acts, errors or omissions of AEDA, CLIENT will hold harmless, defend and indemnify AEDA from all claims, suits, expenses or damages arising from or alleged to arise from exposure to or inhalation of asbestos, asbestos fibers or hazardous waste.

Nothing in this Agreement shall impose liability on AEDA for claims, lawsuits, expenses of damages arising from, or in any manner related to, the exposure to or the handling, manufacture or disposal of asbestos, asbestos products, or hazardous waste in any of its various forms, as defined by the Environmental Protection Agency.
24. SEISMIC DESIGN: If the project is located in New York State, it will be designed in accordance with the structural requirements of the Building code of New York State.

Otherwise, the structure will have some seismic resistance, however, seismic design will not be incorporated in the structural design of the project unless specifically requested by CLIENT as an additional service.
25. CONSTRUCTION PHASE SERVICES: Where AEDA'S services do not include review or site observation of the contractor's work and performance, CLIENT agrees to defend, indemnify, and hold harmless AEDA from any claim or suit whatsoever, including, but limited to all payments, expenses or costs involved, arising from or alleged to have arisen from the contractor's performance or the failure of the contractor's work to conform to the design intent and the contract documents. AEDA agrees to be responsible for its own sole negligent acts, errors or omissions.

- END OF AGREEMENT -



Architectural &
Engineering
DESIGN
Associates P.C.

2018 FEE SCHEDULE

HOURLY RATES

• Principal Architect/Engineer	\$100.00/hr
• Project Architect/Engineer	\$ 85.00/hr
• Intern Architect/Engineer	\$ 75.00/hr
• Architectural/Engineering Technician	\$ 65.00/hr
• Project Manager	\$ 65.00/hr
• Clerical staff	\$ 40.00/hr

EXPENSES

• 24" x 36" B&W Bond	\$4.00/page
• 24" x 36" Color Bond	\$8.00/page
• 24" x 36" Mylar	\$15.00/page
• 12" x 18" B&W Copies	\$1.50/page
• 12" x 18" Color Copies	\$2.50/page
• 11" x 17" B&W Copies	\$1.25/page
• 11" x 17" Color Copies	\$2.25/page
• 8.5" x 11" Color Copies	\$1.00/page
• 8.5" x 11" B&W copies	\$.15/page
• File Scan to disk	\$10.00
• Postage	Invoice Cost
• UPS/FedEx overnight charges	Invoice Cost
• Consultants	Invoice Cost
• Mileage	\$.60/mile

* All final expenses incurred are plus labor.

** All final invoices of hourly rates and expenses will be subject to a 5% overhead and 5% profit markup.

ALL STATE CONSTRUCTION, INC.

Phone (860) 678-0678 * 449 Cooke Street, P.O. Box 805 * Farmington, Connecticut 06034 * Fax (860) 676-8910

City of Plattsburgh
Public Works Department
215 Idaho Avenue
Plattsburgh, NY 12903

August 13, 2018

Re: Park Avenue Street Closure for delivery of HTHW
Generator for SUNY Plattsburgh Central Plant

City Council,

This letter is to request to temporarily close off Park Avenue in the City of Plattsburgh to allow for delivery of a HTHW Generator to SUNY Plattsburgh's Central Plant. The address where the work is to take place is 34 Sanborn Avenue. Due to the size of truck required to deliver the equipment, we will need to block most of Park Avenue during the delivery. We will also need to install some protection along the curbing to allow for delivery truck to back over it to reach the crane pick location. It will be safer to have a full road closure for the time of this work then it would be to have flaggers stopping traffic as needed.

The proposed date and time of the work is September 6th, 2018 from 7:00am until approx. 3:30 pm. Signage will be provide as shown on the attached drawing.

A second closure will be closer to ^{MAY} March 2019 when HTHW #4 is ready for delivery. We anticipate that this will be very similar to the proposed delivery procedure for Generator #3.

Please find the following attached:

- Traffic plan for Road Closure
- Delivery plan showing overhead view of truck path and obstacles
- Street view showing the expected path of the delivery truck
- Cut sheet showing truck with dimensions
- Cut sheet showing Crane with dimensions

The plan for delivery is as follows:

1. Setup road closure signage at beginning of shift on day of delivery
2. Crane to arrive early in the shift or day before and have outriggers set prior to arrival of load.
3. Install plates over catch basin. Install gravel ramp along Park Avenue southern curb in area to the east of the catch basin in order to protect existing curb. Truck to arrive via Sanborn Avenue.
4. Truck to pull forward across Park Avenue to northern side of Sanborn Avenue
5. Truck to back up from Sanborn Avenue to the site between the existing catch basin and pole as shown on the attached sketches.
6. Truck to continue backing into site until in position under crane hook.
7. Load to be rigged and lifted by crane straight up.
8. Truck to pull forward once load is safely lifted out of the way.
9. Truck will exist the area via Sanborn Avenue traveling north.

GENERAL / MECHANICAL / CIVIL CONTRACTORS

Major Contractor #MCO.0901120 * Mechanical Contractor #MEC.0001084

Holders of the "U", "S", "H" & "R" Stamps · Member of the A.S.M.E.

www.allstateconstructioninc.com

AA/EOE

ALL STATE

CONSTRUCTION, INC.

Phone (860) 678-0678 * 449 Cooke Street, P.O. Box 805 * Farmington, Connecticut 06034 * Fax (860) 676-8910

10. Crane to lower load onto dollies on existing driveway.
11. Gravel that was spread along curb to be removed. Plate over catch basin to be removed.
12. Road closure and detour signage to be removed and Park Avenue reopened.

We anticipate that this work will take one day. If you have any further questions please feel free to reach out to the contact information below.

Sincerely,

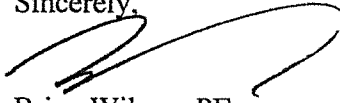

Brian Wilson, PE
Project Manager
All State Construction, Inc.
860-250-8942
bwilson@allstateconstructioninc.com

GENERAL / MECHANICAL / CIVIL CONTRACTORS

Major Contractor #MCO.0901120 * Mechanical Contractor #MEC.0001084

Holders of the "U", "S", "H" & "R" Stamps · Member of the A.S.M.E.

www.allstateconstructioninc.com

A A / E O F



Location of Road Closure

Google

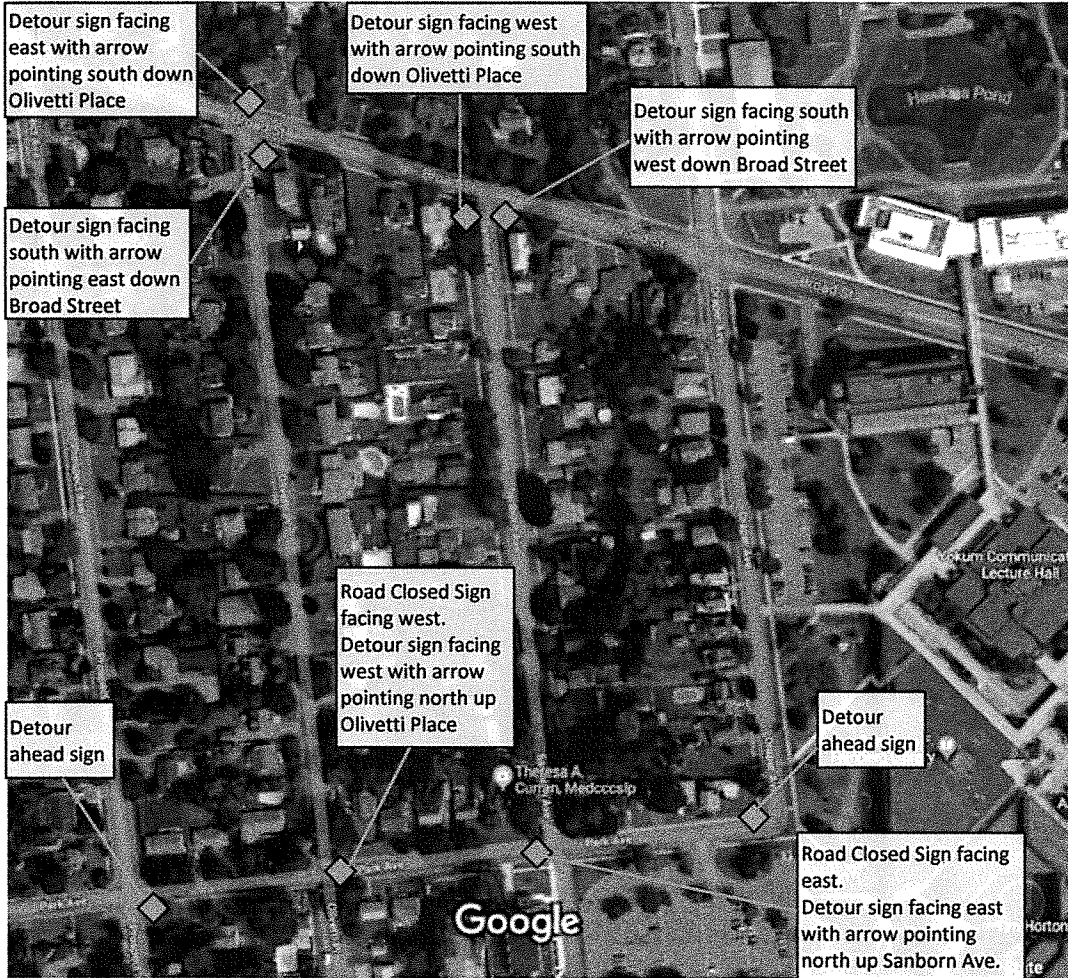

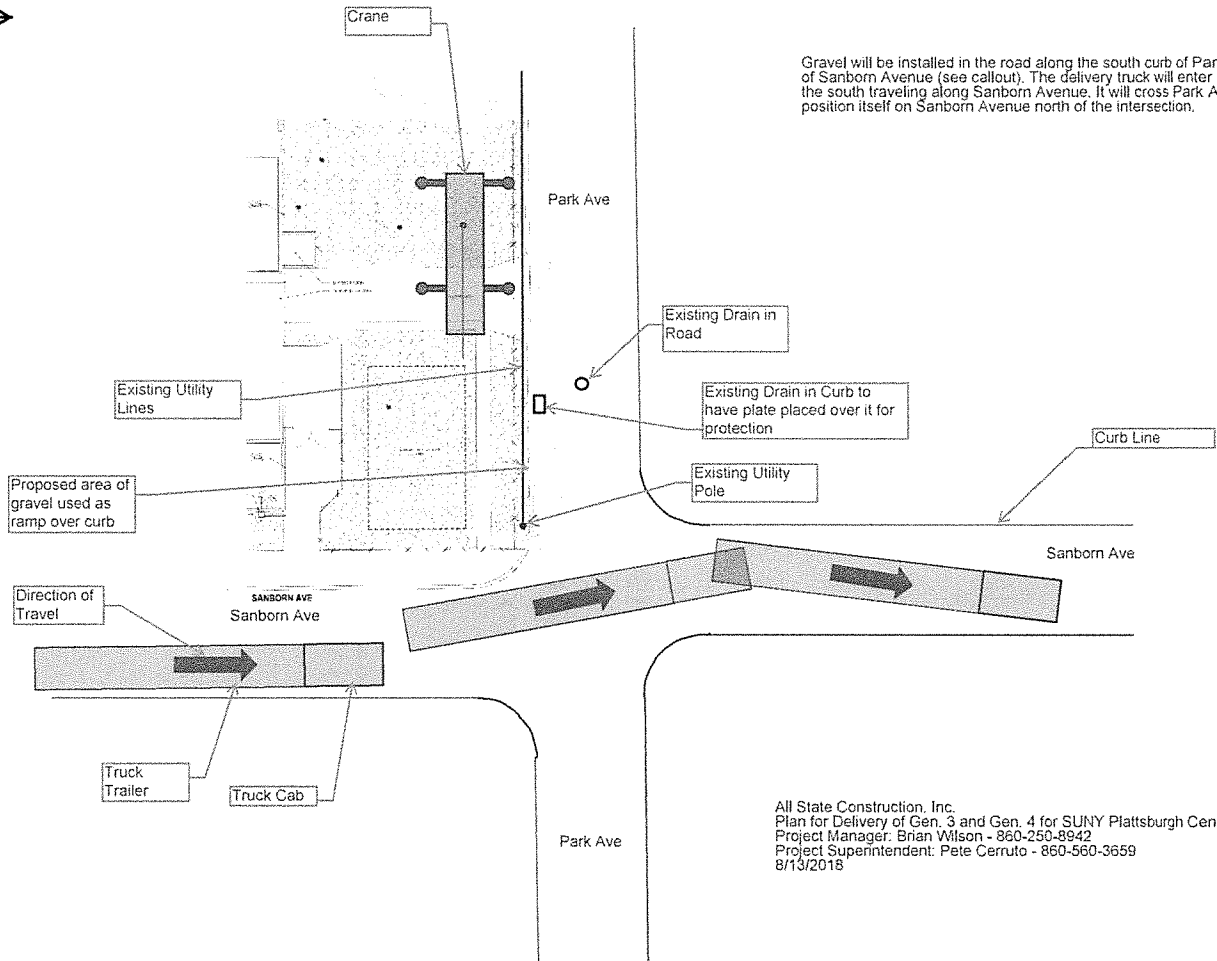

All State Construction, Inc.
Plan for Delivery of Gen. 3 and Gen. 4 for SUNY Plattsburgh Central Plant
Project Manager: Brian Wilson - 860-250-8942
Project Superintendent: Pete Cerruto - 860-560-3659
8/13/2018

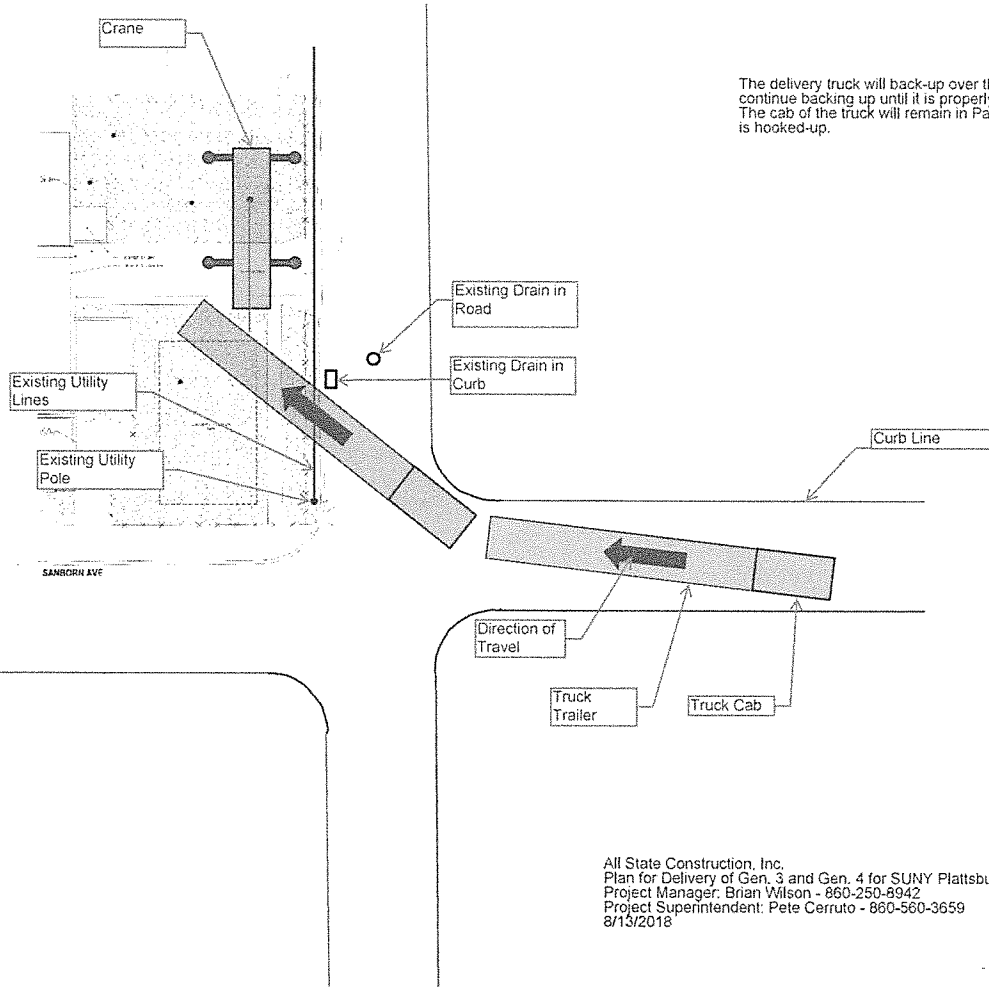

The delivery truck will back-up over the curb into the site, it will continue backing up until it is properly positioned under the crane. The cab of the truck will remain in Park Avenue while the load is hooked-up.

All State Construction, Inc.
Plan for Delivery of Gen. 3 and Gen. 4 for SUNY Plattsburgh Central Plant
Project Manager: Brian Wilson - 860-250-8942
Project Superintendent: Pete Cerruto - 860-560-3659
8/13/2018



The delivery truck will have its cab remain in Park Avenue while the load is hooked up and picked. The crane will lift the load and truck will drive forward out of the site. The load will then be lowered onto the boiler dollies for movement into the Central Plant.

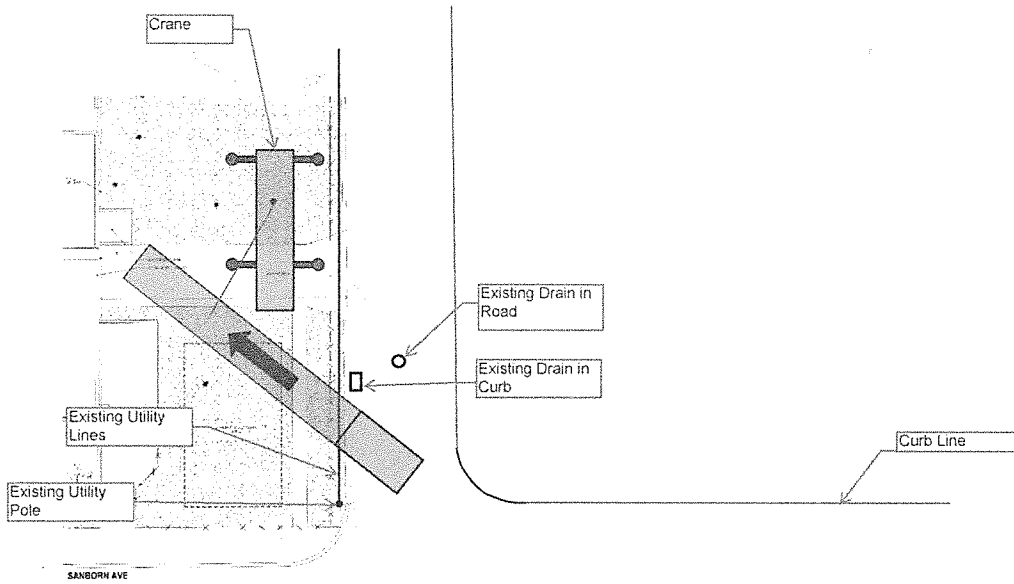

All State Construction, Inc.
Plan for Delivery of Gen. 3 and Gen. 4 for SUNY Plattsburgh Central Plant
Project Manager: Brian Wilson - 860-250-8942
Project Superintendent: Pete Cerruto - 860-560-3659
8/13/2018

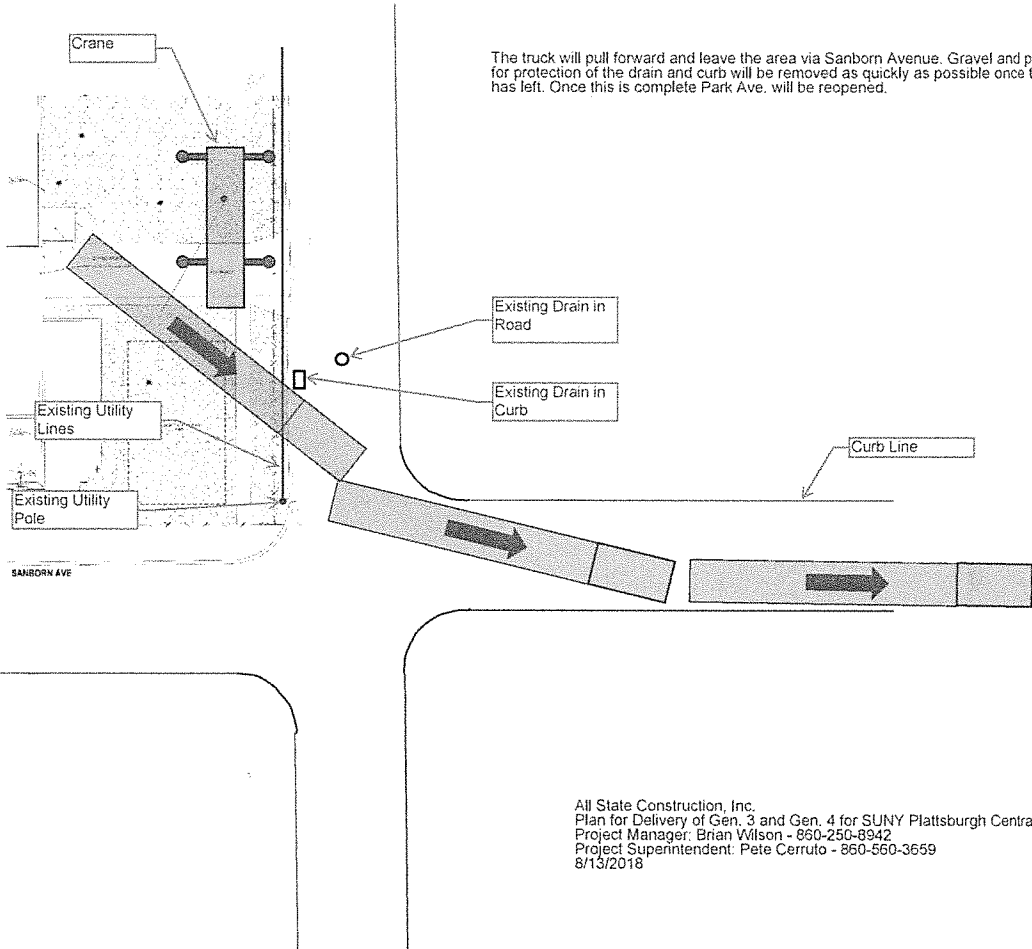

The truck will pull forward and leave the area via Sanborn Avenue. Gravel and plates placed for protection of the drain and curb will be removed as quickly as possible once the truck has left. Once this is complete Park Ave. will be reopened.

All State Construction, Inc.
Plan for Delivery of Gen. 3 and Gen. 4 for SUNY Plattsburgh Central Plant
Project Manager: Brian Wilson - 860-250-8942
Project Superintendent: Pete Cerruto - 860-560-3659
8/13/2018

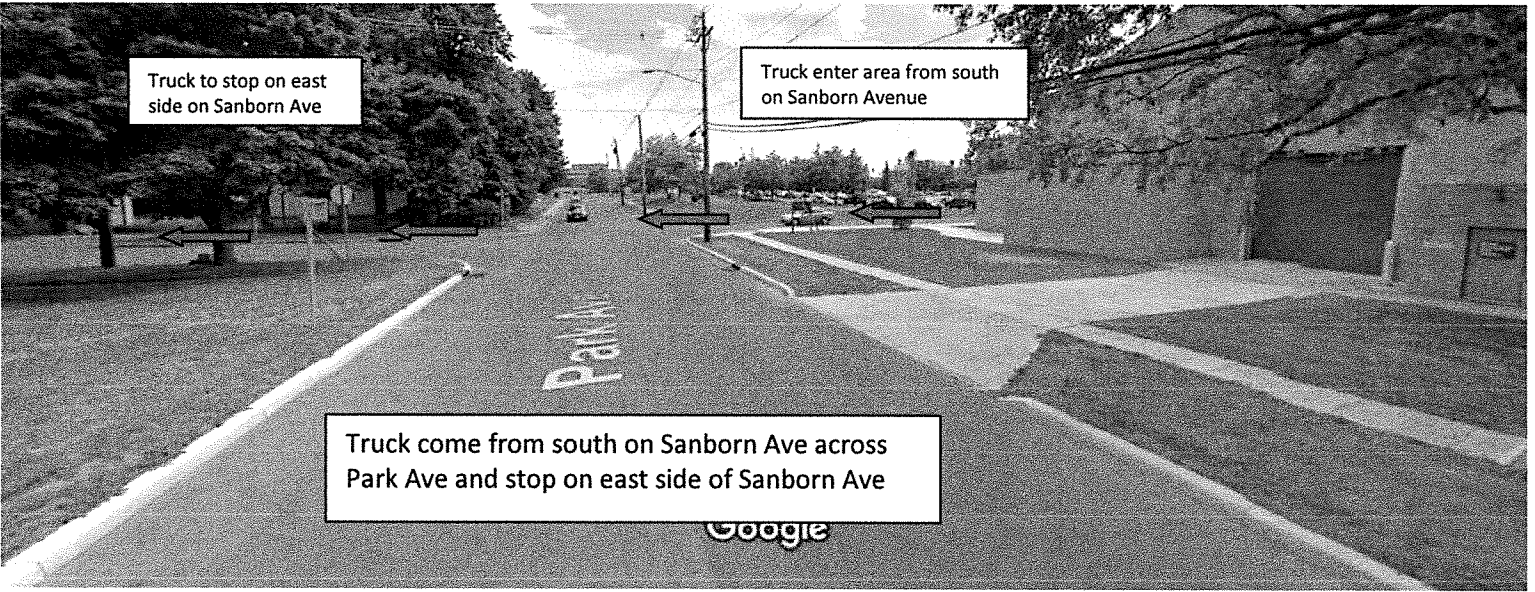

Truck to stop on east side on Sanborn Ave

Truck enter area from south on Sanborn Avenue

Truck come from south on Sanborn Ave across Park Ave and stop on east side of Sanborn Ave

Google

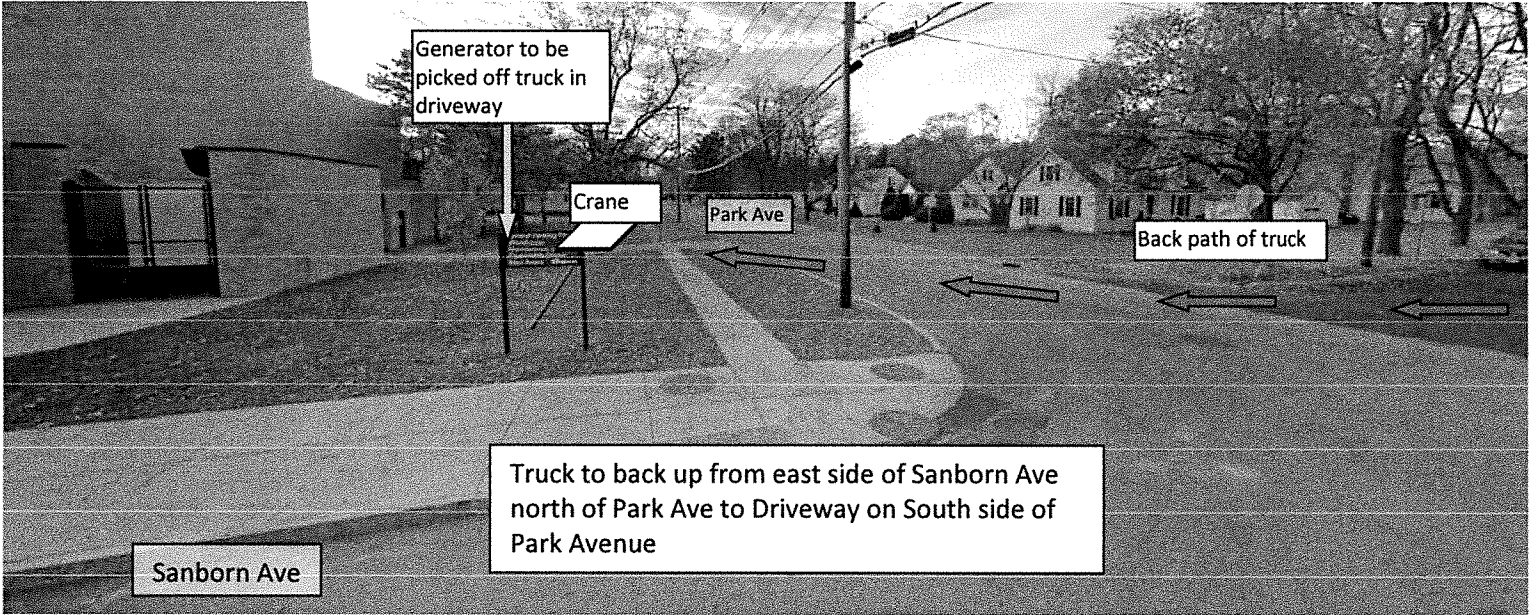

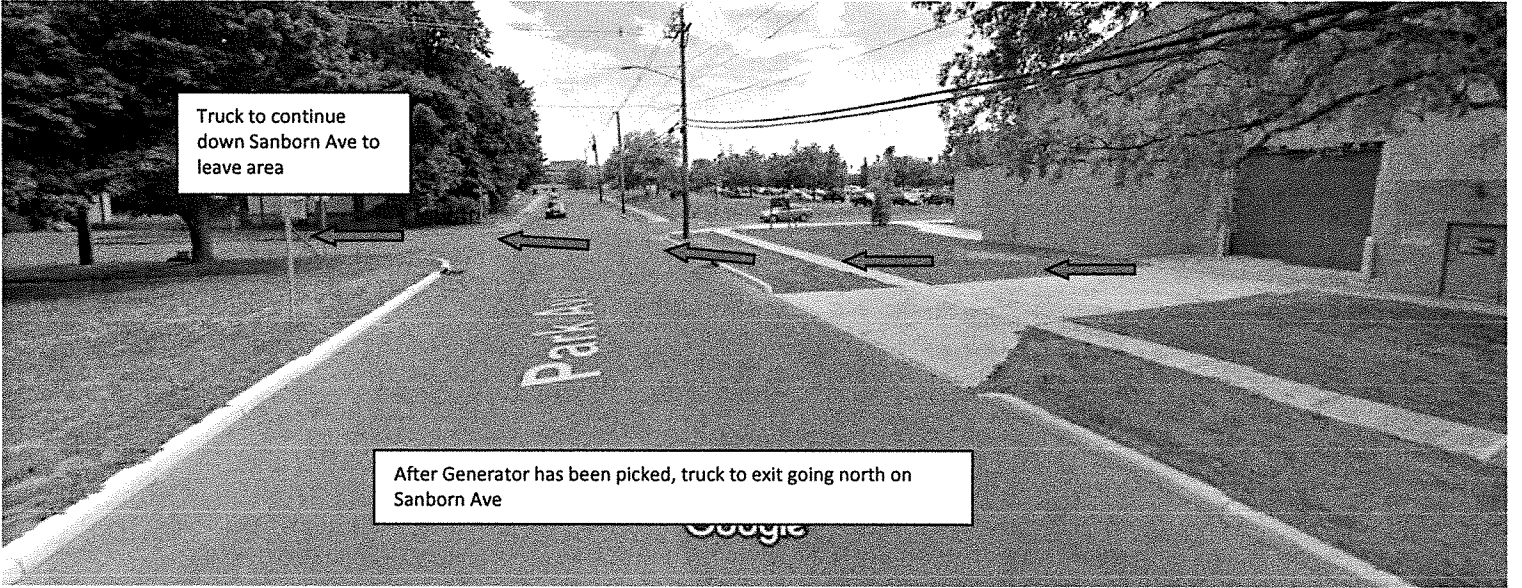

Truck to continue
down Sanborn Ave to
leave area

After Generator has been picked, truck to exit going north on
Sanborn Ave

Google

97'-4-1/2"

All lengths in meters and weights in kilograms Printout of Load Xpert software

Overall Length: 29.68

65'-8-3/16"

15'-10" top to ground

12'-0" wide

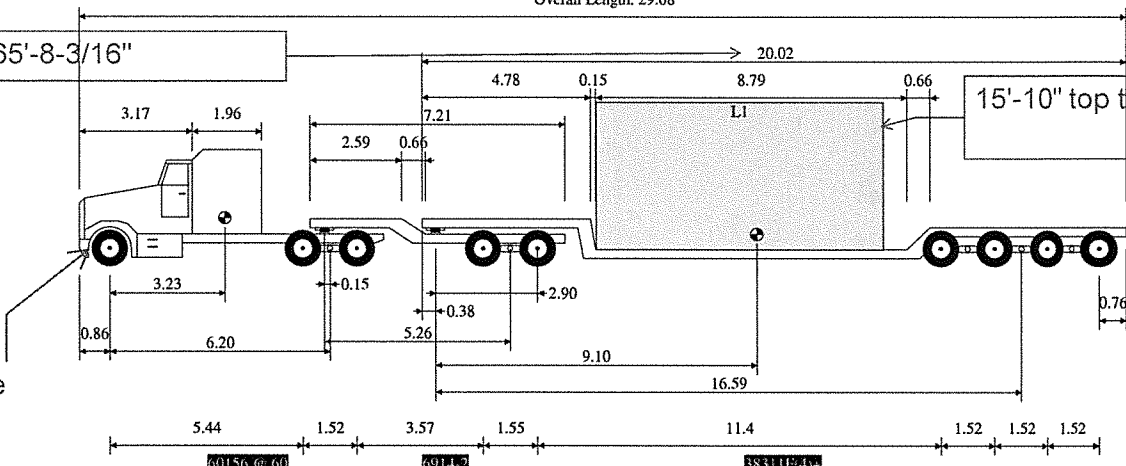

Axle Loads (kg)	#1	#2	#3	#4
Tare:	5523	8461	5961	8720
Accessories:	0	0	0	0
Payload:	188	7466	11321	20487
Total:	5712	15927	17282	29207

63196# (31.6t)

87000# (43.5t)

	Unit 1 (Tractor)	Unit 2 (Jeep)	Unit 3 (Lowbed)	Vehicle
Tare weight (kg):	11405.0	3460.0	13800.0	28669.0
Accessories(kg):	0.0	0.0	0.0	0.0
Payload (kg):	0.0	0.0	39462.5	39462.5
Total (kg):	11405.0	3460.0	53262.5	68127.5

150,196# (75t)

Title: Simoneau	Company:	Date:
	By:	Dwg No.:

General Dimensions

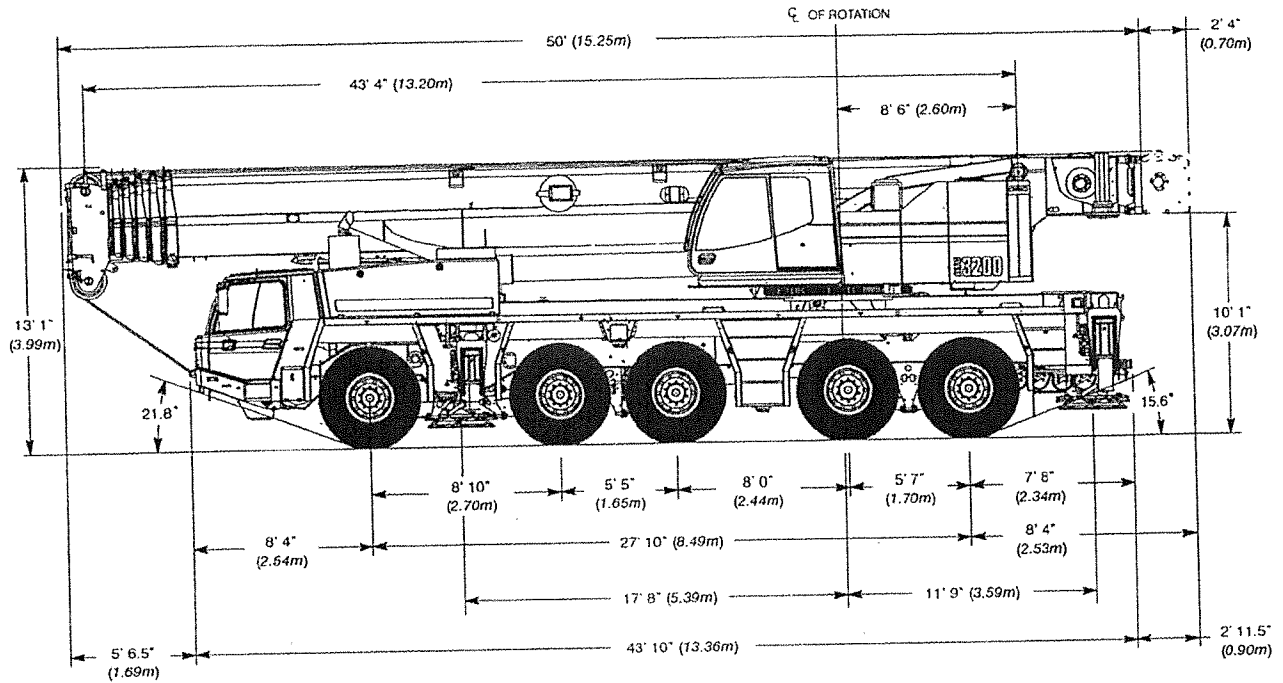

Turning Radius	20.5R25		16.0R25	
	English	Metric	English	Metric
Wall to wall over carrier	36' 0"	11.0m	35' 9"	10.9m
Wall to wall over boom	38' 4"	11.7m	36' 1"	11.6m
Wall to wall over boom attachment	40' 7"	12.4m	40' 4"	12.3m
Curb to curb	32' 2"	9.80m	31' 11"	9.72m
Centerline of tire	31' 5"	9.6m	31' 2"	9.5m

Tail Swing	English	Metric
With auxiliary winch	16' 8"	5.1m
Without auxiliary winch	14' 5"	4.4m

Overall Width	English	Metric
With up to 81,570 lb (37,000kg) counterweight	9' 10"	3.0m
With 112,435 lb (51,000kg) counterweight	15' 1"	4.6m

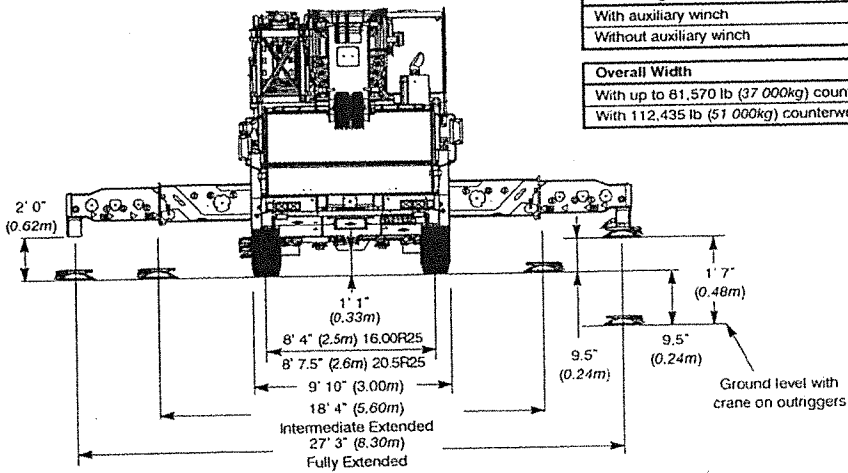

Not To Scale



Plattsburgh, New York

Kristofer Gushlaw, PO
Chief Plant Operator
Water Resource Recovery Facility

53 Green Street
Plattsburgh, NY 12901
Phone: 518-536-7519
Fax: 518-563-6083
gushlawk@cityofplattsburgh-ny.gov

May 7, 2019

Honorable Mayor Colin Read
and Members of the Common Council
41 City Hall
Plattsburgh, NY 12901

**RE: Drummac Septic Service
Contract #2017-08
Hauling of Sludge from the WRRF- Contract Extension (2nd)**

Dear Mayor Read and Councilors:

The above referenced contract expires on May 31, 2019. The contract includes an option for extending the period of service for an additional year (up to four times). Drummac Septic Service has requested that the second one-year extension option be utilized. It is requested that authorization be given to extend the period of service to May 31, 2020.

An estimated total lump sum of \$186,224.48 was provided on the Bid Proposal Form included with the original bid submission. This sum will remain unchanged for the extension period of June 1, 2019 - May 31, 2020. The WRRF will budget accordingly for 2020 (based on the estimated lump sums and actual costs). A copy of the letter dated March 27, 2019 from Mike Medor (owner) is attached for your convenience.

Best Regards,

Kristofer Gushlaw, PO
Chief Plant Operator

Drummac Septic Service

P.O. Box 314
Highgate Center, VT 05459
802-868-3247

March 27 2019

Kristofer Gushlaw
52 Green Street
Plattsburgh NY 12901

RE: Sludge Hauling for WPCP-Contract #2017-08

Dear Kris:

Drummac Septic Service is interested in extending the sludge hauling for the Water Pollution Control Plant for one year.

Please let me know if you have any further questions.

Thank you,

Michael Medor
Branch Manager



Plattsburgh, New York

Kristofer Gushlaw, PO
Chief Plant Operator
Water Resource Recovery Facility

53 Green Street
Plattsburgh, NY 12901
Phone: 518-536-7519
Fax: 518-563-6083
gushlawk@cityofplattsburgh-ny.gov

May 7, 2019

Honorable Mayor Colin Read
and Members of the Common Council
41 City Hall
Plattsburgh, NY 12901

**RE: Total Control System Services, Inc.
Contract #2017-09
Instrumentation – Preventative Maintenance Serves for the WRRF-
Contract Extension**

Dear Mayor Read and Councilors:

The above referenced contract expires on June 27, 2019. The contract includes an option for extending the period of service for an additional year (up to two times). Total Control System Services, Inc. has requested that the final one-year extension option be utilized. It is requested that authorization be given to extend the period of service to June 27, 2020.

An estimated total lump sum of \$36,212 was provided on the Bid Proposal Form included with the original bid submission. This sum will remain unchanged for the extension period of June 28, 2019 – June 27, 2020. A copy of the letter dated April 12, 2019 from Frederick Pawlak is attached for your convenience.

Best Regards,

Kristofer Gushlaw, PO
Chief Plant Operator

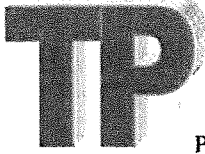

TEMP-PRESS, INC.

30 Hytec Circle, Suite 200

Rochester, NY 14606

Phone: 585-235-6160 ♦ Fax: 585-235-1053 ♦ Email: sales@tempress.com

Friday, April 12, 2019

Kristofer Gushlaw
Plattsburgh WPCP
53 Green St.
Plattsburgh, NY 12901

Re: Contract # 2017-09
Instrumentation – Preventive Maintenance Services for the WPCP

Dear Kris:

Total Control System Services, a division of Temp-Press, Inc. would like to extend Contract # 2017-09 for one additional year.

We agree that all terms of the present contract will remain the same. When complete, please forward the new maintenance contract for my signature.

We look forward to working with you again in the coming year.

Sincerely,

Frederick J. Pawlak
Service

FJP/cj



Plattsburgh, New York

Kristofer Gushlaw, PO
Chief Plant Operator
Water Resource Recovery Facility

53 Green Street
Plattsburgh, NY 12901
Phone: 518-536-7519
Fax: 518-563-6083
gushlawk@cityofplattsburgh-ny.gov

May 7, 2019

Honorable Mayor Colin Read
and Members of the Common Council
41 City Hall
Plattsburgh, NY 12901

**RE: Triangle Electrical Systems, Inc.
Contract #2018-04: Electrical Services for the WRRF
Contract Extension Request**

Dear Mayor Read and Councilors:

The above referenced contract expires on June 27, 2019. The contract includes an option for extending the period of service for an additional year (up to two times). Triangle Electrical Systems, Inc. has requested that the first one-year extension option be utilized. It is requested that authorization be given to extend the period of service to June 27, 2020.

The wages have been adjusted to match the CPI-U (published by the Dept. of Labor for the Northeast Urban), and not to exceed 3% as outlined in the original bid packet (Section 2.6 E). A copy of the letter dated May 3, 2019 from Linda Brienza is attached for your convenience. This letter also outlines the new wage rates.

Best Regards,

Kristofer Gushlaw, PO
Chief Plant Operator

TRIANGLE

ELECTRICAL SYSTEMS, INC.

WWW.TRIANGLESYSTEMS.COM
126 IDAHO AVENUE
PLATTSBURGH, NY 12903
PHONE (518) 562-5425

May 3, 2019

Kris Gushlaw
Water Resource Recovery Facility
53 Green Street
Plattsburgh, NY 12901

Re: Renewal of Contract #2018-04
Electrical Services for WPCP

Dear Kris:

I am writing today to notify you of Triangle Electrical Systems, Inc. intent to extend the above referenced contract for another year. The current contract expires on June 27th 2019.

We would like to renew the contract at the below rates:

Straight Time (WPCP)	=	\$ 86.00/hour
Overtime	=	\$116.00/hour
Sunday's & Holidays	=	\$147.00/hour
Straight Time (other City Depts)	=	\$ 92.50/hour
SCADA Programming/Design/ Communications/ Greg Brienza=		\$98.50/hour

The above rates if acceptable will be effective on July 1, 2019.

Thank you for the opportunity to assist you over the past year and we look forward to continuing our relationship. If you have any questions please give me a call.

Sincerely,

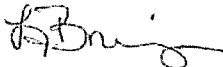

Linda Brienza

Petition to City of Plattsburgh

November 30, 2018

Nicholas A. Pope and Jessica Guerin

Arnie's Restaurant

(518) 491-6196

We, the undersigned, request the City of Plattsburgh name the proposed new parking lot **Arnold Pavone Square** for his service to our community for nearly 70 years.

Name:	Address:	Signature:
Laura Cohean	82 Margaret St.	Laura Cohean
Tom Lavin	379 Cornubland Island Rd	Tom Lavin
Shirley Evans	7 Oakdale Drive, Peru	Shirley Evans
Chai McIsland	12 Tremblay Ave Plattsburgh	Chai McIsland
John A. DeRoche		John A. DeRoche
Susan Oliver	38 W. Church St. West Chazy NY	Susan Oliver
Leo Oliver	38 W Church St. West Chazy NY	Leo Oliver
Tom Chaskey	46 Tremblay Ave Plattsburgh, NY	Tom Chaskey
Sandy Thornton	112 Akkey Rd Morrison NY	Sandy Thornton
Awen Thornton	112 Akkey Rd M-Ville NY 12962	Awen Thornton
Money Letore	50 Akkey Rd MORRISONVILLE NY 12962	Money Letore
Stephan Letore	" " " " " "	Stephan Letore
Peter Ventry	27 Lincoln Ave Binghamton NY 13905	Peter Ventry
Alfred Grant	1 Set Point, Plattsburgh, NY 12901	Alfred Grant
Ed Pavone	3 St Louis Plattsburgh NY	Ed Pavone

Petition to City of Plattsburgh

November 30, 2018

Nicholas A. Pope and Jessica Guerin

Arnie's Restaurant

(518) 491-6196

We, the undersigned, request the City of Plattsburgh name the proposed new parking lot Arnold Pavone Square for his service to our community for nearly 70 years.

(J)

Name:

Address:

Signature:

J. L. LETOURNEAU

38 Woodhaven Dr, NY 12979
38 Woodhaven Dr. K.P.

J. Letourneau
Jan Letourneau

JAN LETOURNEAU

24 Bailey Ave
Plattsburgh NY
12901

Kelly Penfield

Kelly Penfield

Melissa McManus

3 Kavanagh Drive
Rouses Point, NY 12979
Port Jervis

Melissa McManus

Kristi Laddar

Perau, NY 12972

Kristi Sullivan

Roberta Sullivan

Perau, NY 12972

David Sullivan

David Sullivan

Bob & Sue Papa - Provost Severn MD

21144
Sue Papa Pope

Kayla Boise

29 Tom Miller rd
Cadyville, N.Y.

Debra A. Pope
Debra Brown

Debbie Depo

Morrisville, NY

Debra Brown

Karen Reil Latour

30 Hartwell St. Plattsburgh

Karen Latour

Steve & Sue Merchant

15 Clinton St. Rouses Point, NY

Sue Merchant

Morgan Wilkins

202 Rabideau St Cadyville NY

Morgan Wilkins

Hannie Miller-Beaudin

Peter Beaudin

Willard Miller

Petition to City of Plattsburgh

November 30, 2018

Nicholas A. Pope and Jessica Guerin

Arnie's Restaurant

(518) 491-6196

We, the undersigned, request the City of Plattsburgh name the proposed new parking lot Arnold Pavone Square for his service to our community for nearly 70 years.

16

Name:

Address:

Signature:

Sue Frechette

57 Melody Lane

Sue Frechette

Blake Frechette

57 Melody Lane

Blake Frechette

Margaret Bechara 906 Route 9B

Margaret Bechara

Raymond Bechara 906 Route 9B

Raymond R. Bechara

ROU + BARK KEEGAN 70 BOX 01 WILMINGTON NY

Rou Keegan

Bark / Jerry McGovern 12997 63 PLEASANT ST PERU

Jerry McGovern

Joe & Carole Garcia 217 Cornelia St

Joe R. Garcia

Tiffany + Cary Garcia 67 Waterbury St

Tiffany Garcia

Steph McFadden

45 South Place

Steph McFadden

Elyse Kaido

10859 Pleasant Dept Rd
Rethusen NY

Elyse Kaido

Brandi Joyal

2 River St. Hgts

Brandi Joyal

Kathy Ann

11 Victoria Way
Plattsburgh NY

Kathy Ann

Petition to City of Plattsburgh

November 30, 2018

Nicholas A. Pope and Jessica Guerin

Arnie's Restaurant

(518) 491-6196

We, the undersigned, request the City of Plattsburgh name the proposed new parking lot Arnold Pavone Square for his service to our community for nearly 70 years.

20

Name:

Address:

Signature:

Virginia M. Johnson

49 Maryland Rd. Plattsburgh

Virginia M. Johnson

Robert A. Johnson

49 Maryland Rd. Robert Johnson

Dept NY 12935

Shaun Brunell

350 Forest Rd, Ellenburg

Shaun Brunell

Brooke Lamere

67 Dubois Rd

Brooke Lamere

Dan Brunell

350 Forest Rd Ellenburg

Dan Brunell

Branden Lamere

67 Dubois Rd, Champlain, NY

Branden Lamere

ALEX CHIOB

27 CITY HILL PLACE

Alex Chio

Ron Garwood

36 Letaev Ave

Ronald E. Garwood

LISA ROBINSON

40 HILLCREST AVE

Lisa A. Robinson

RICHIE NAVIN

95 COURT ST

Richie Navin

Bruce

172 mmmt

Bruce

Aric Gekups

274 Town Hill Rd

Aric Gekups

Clinton Bell

WAT DRAZ, NY 12992

Clinton Bell

Keith Cressley

383 Rock Rd. Peru, n.y.

Keith Cressley

Daniel Samuell

24 Wheeling Ave

Daniel Samuell

Robert A. Johnson

7 Arrowhead, Monticello

Robert A. Johnson

Kevin + Jeannine Murphy

7 Robinson Terrace, Platts

Kevin + Jeannine Murphy

Julie M. Stalker

1184 County Rte 23 Burke N.Y.

Julie M. Stalker

Sally Louisa

5 Maiden Ln. Lamy NY

Sally Louisa

Petition to City of Plattsburgh

November 30, 2018

Nicholas A. Pope and Jessica Guerin

Arnie's Restaurant

(518) 491-6196

We, the undersigned, request the City of Plattsburgh name the proposed new parking lot Arnold Pavone Square for his service to our community for nearly 70 years.

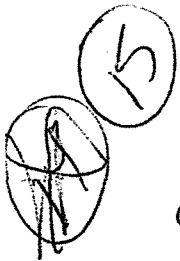

Name:

Address:

Signature:

Collin McCloy
Anna Pavone
mark & Janice Dosiek

244 ELM ST. APT. 2
31 PROSPECT ave.
624 Wilfred King Rd
Ellenburg Depot, NY.

Arnold Pavone
Janice Dosiek

Carl Walker

North Catherine St
ST Charles St
61 Tremblay Ave.
Plattsburgh

Carl Walker
Conne Labonde

Dennis Bowler

Connie Lalonde

Donna Darrah

1670 military Tpk
Plattsburgh Tpk

Donna Darrah

Gayle Bottoms

6 Spreng Circle Plattsburgh

Gayle Bottoms

Ray Gagnon
~~Ray Gagnon~~

7 Saratoga Court Platts.
70 Sandra Ave

Ray Gagnon
Heather Bedard
Lynn Bedard

Rosemary Bedard

" " "

Larry Trzaskos

64 Tunnel Lane Willsboro

Larry Trzaskos

Patricia Trzaskos
Jeffrey Sears

64 Tunnel Lane Willsboro

Patricia Trzaskos

Petition to City of Plattsburgh

November 30, 2018

Nicholas A. Pope and Jessica Guerin

Arnie's Restaurant

(518) 491-6196

We, the undersigned, request the City of Plattsburgh name the proposed new parking lot Arnold Pavone Square for his service to our community for nearly 70 years.

16

Name:	Address:	Signature:
WM. PETERS	222 DICKSON PT. Rd.	
Tina Recor	14 Pine Ridge Dr. Missoula	Tina Recor
Brenda Liberty	21 Smart Road Plattsburgh NY 12901	Brenda Liberty
Debbie Miner	10180 State Rt 3, Vermontville,	Deborah G. Miner
THOMAS SHAWER	109 JOHN BOSWELL RO. ^{NY 12989} PAID NY 12972	
David Moore	2300 Ruger St # 3	
Jean Moore	64 Coogan Ave	
Billy Wells	164 Aysable St. #3 Keeseville, NY 12944	B. Wells
DAVE BAKER	20 Adrien Ln	Dave Baker
Sue Baker	" " "	
Mary ROSTAK	4951 S. CATH ST Plattsburgh NY	Mary Rostak
ED ROSTAK		
Konnor Baker	22 Brinkerhoff St. Apt. 3	Konnor Baker
Angela St. John	45 Susan Lane	Angela M. St. J.
Lillian DUBREY	39 SAILEY AVE	Lillian Dubrey
KYLE BRANCH	70 DEPT. 4 + APT 2	

Petition to City of Plattsburgh

November 30, 2018

Nicholas A. Pope and Jessica Guerin

Arnie's Restaurant

(518) 491-6196

We, the undersigned, request the City of Plattsburgh name the proposed new parking lot Arnold Pavone Square for his service to our community for nearly 70 years.

14

Name:

Address:

Signature:

Patricia Curran

121 maine Rd
Plattsburgh NY
12903

Patricia Curran

Carol Latinville

65 Adirondack Lane
Plattsburgh NY 12903

Carol Latinville

Susan Phillips

37 MAINE Rd.
Plattsburgh, NY 12903

Susan Phillips
Don Romel
4 Lynde St
Plattsburgh
Tom Gregware

Tom & Bonnie Gregware

19 Tom Miller Rd
Plattsburgh

Thor Murphy

116 Courts Plattsburgh NY 12901

Thor Murphy

Fran Berger

17 Elm Perle
17 Elm St Perle

Fran Berger

Doug Berger

Doug Berger

Mary Heslin

134 Algoma
5391 Perle St

Mary Heslin

Mary & John Ernst

47 Maine Rd
Plattsburgh, NY 12903

Mary & John Ernst

Al Svoboda

22 Halsey Ct
Plattsburgh NY
154 Maryland Rd

Al Svoboda

Petition to City of Plattsburgh

November 30, 2018

Nicholas A. Pope and Jessica Guerin

Arnie's Restaurant

(518) 491-6196

We, the undersigned, request the City of Plattsburgh name the proposed new parking lot Arnold Pavone Square for his service to our community for nearly 70 years.

2

Name:

Address:

Signature:

Debra Tyler

2 Dward St Apt A.
Plattsburgh, NY 12901

Debra Tyler

Annette Newell

155 Dickson Pt Rd
Plattsburgh NY 12901

Annette Newell

Ann Fortin

260 Moffitt Rd
Plattsburgh, NY 12901

Ann Fortin

RICHARD CORROW

155 DICKSON PT RD
PLATTSBURGH N.Y. 12901

Richard Corrow

Jim & Kathy True

28 Mannix Rd,
Peru, N.Y. 12972

Jim & Kathy True

Joan & George Kurz
DEBORAH M. WELLS

5-4 Lakeshore Rd
34 MAIN Mill St
Plattsburgh

Joan Kurz

Deborah M Wells

RICH & JUDY GUGLIELMO

71 WINDSWEEP LANE
Plattsburgh, N.Y. 12901

Judy Guglielmo

Amy Powell

122 BOALST
PLATT

Amy Powell

Linda McCarty

130 Ruger St

Linda McCarty

Thomas McCarty

" " Platts

Thomas McCarty

Petition to City of Plattsburgh

November 30, 2018

Nicholas A. Pope and Jessica Guerin

Arnie's Restaurant

(518) 491-6196

We, the undersigned, request the City of Plattsburgh name the proposed new parking lot Arnold Pavone Square for his service to our community for nearly 70 years.

(b)

Name:	Address:	Signature:
Elizabeth Suffell	12 Dayton Blvd Plattsburgh, NY 12901	Elizabeth Suffell
Bill BETS	90 ROGATE PLATTS, NY	[Signature]
Kate Patrick	98 Rugar St Plattsburgh NY	[Signature]
MICK PETRIE	20 COUNTRY COMMONS, VERGENNES VT	[Signature]
Kim Cole	2141 Rano Hill RD ALTONA, NY	[Signature]
Wozella Dondolan	2141 Rano Hill RD ALTONA, NY	[Signature]
Susan J Kelton	32 Cogan Ave Plattsburgh NY	[Signature]
BARRY St Louis	57 PALMER ST "	[Signature]
Kevin L Barbano	83 Sailer Ave Platts NY	[Signature]
John: 'Vicki' Masella	60 club Rd, unit 103 Plattsburgh	[Signature]
Ch de Ligne'	4 Steen + St Plattsburgh, NY	[Signature]
Edward Eisele (mailman)	8 Button Brook Pkwy Perce NY	[Signature]
Jody Brown	122 Sharron Ave. Plattsburgh NY	[Signature]
Melissa Craney	34 Broad St. Plattsburgh NY	[Signature]

Petition to City of Plattsburgh

November 30, 2018

Nicholas A. Pope and Jessica Guerin

Arnie's Restaurant

(518) 491-6196

We, the undersigned, request the City of Plattsburgh name the proposed new parking lot Arnold Pavone Square for his service to our community for nearly 70 years.

18

Name:	Address:	Signature:
Bruce Lavalley	1112 Cumberland Hill	<i>[Signature]</i>
BETTY POITRAS	131 MONCALM AVE.	<i>[Signature]</i>
PAMELA LAVALLEY	1112 CUMBERLAND HILL	<i>[Signature]</i>
SUE BAKER	127 SO. PERU ST. APT. 2	<i>[Signature]</i>
Heather Silver	376 DICKSON PT RD.	<i>[Signature]</i>
Scott LaMure	30 Vaughn Road	<i>[Signature]</i>
Kelley Gilmore	507 W. Hill Rd	<i>[Signature]</i>
RICK LAMBERTON	208 BOUCHARD DR.	<i>[Signature]</i>
WALLACE A DAY	4235 RIG	<i>[Signature]</i>
ROBERT SALEMBIER	13 WASHINGTON PL	<i>[Signature]</i>
KEITH DEFAYETTE	7 RIVER BEND DR PLATTSBURGH NY	<i>[Signature]</i>
RON SANTON	84 SALMON RIVER AVE.	<i>[Signature]</i>

Petition to City of Plattsburgh

November 30, 2018

Nicholas A. Pope and Jessica Guerin

Arnie's Restaurant

(518) 491-6196

We, the undersigned, request the City of Plattsburgh name the proposed new parking lot Arnold Pavone Square for his service to our community for nearly 70 years.

Name:	Address:	Signature:
① Pamela M Perry	81 Lafayette St Plattsburgh	Pamela M Perry
Sara Perry	Prospect Ave 143 Lafayette St Plattsburgh	Sara Perry
Tyler Perry	143 Prospect Avenue Plattsburgh NY 12901	Tyler Perry
Debra Rodriguez	12750 Plat St Plattsburgh	Debra Rodriguez
Bruce Stevens	21 CRESCENT DR	Bruce Stevens
C. Anthony Carlongne	27 NEW YORK RD PLATTSBURGH NY	C. Anthony Carlongne
MICHAEL CARLONGNE	PLATTSBURGH	Michael Carlongne
Rob Munn	1996, RT 374 Ellenburg Depot, NY	Rob Munn
Juliet Hill-Munn	"	Juliet Hill-Munn
Rebecca Duquette	2026 RT 22B MORRISONVILLE NY 12962	Rebecca Duquette
Theresa Allen	4 Howard drive Peru NY 12972	Theresa Allen
William Agoney	4 Howard drive Peru NY 12972	William Agoney
David M Duquette	2026 RT 22B MORRISONVILLE NY 12961	David M Duquette

Petition to City of Plattsburgh

November 30, 2018

Nicholas A. Pope and Jessica Guerin

Arnie's Restaurant

(518) 491-6196

We, the undersigned, request the City of Plattsburgh name the proposed new parking lot Arnold Pavone Square for his service to our community for nearly 70 years.

(2)

Name:

Address:

Signature:

STEPHEN S. PETRASHINE
Sharon m Raymond
Danielle marguis
Gavin P Riley
Eileen Gonzalez
Daniele Howard Less
STEVE PERNY

4614 RT 3 Saenik
12 Hendrix Rd m'ville
39 homestead drive
Plattsburgh
256 Margaret St St. 104
Plattsburgh, NY 12901
36 Lafayette St Plattsburgh
NY 12901
2 River Bend Plattsburgh
81 LAFAYETTE ST
PLATTSBURGH
NY 12901

Stephen Petrashine
Sharon Raymond
Danielle Marguis
Eileen Gonzalez
Daniele Howard Less

MIKE LECLAIR
William F. Price

115 CORNELIA ST.
PLATTSBURGH, N.Y.
12901
59 Knob Hill RD
Peru, NY 12872

Mike Leclair
William F. Price

Alan B. Booth
~~ziad sassine~~
ziad sassine

Booth Insurance Agency
20 Brinkerhoff St
Plattsburgh
5748 Peru St
Plattsburgh

A. B. Booth

W

Petition to City of Plattsburgh

November 30, 2018

Nicholas A. Pope and Jessica Guerin

Arnie's Restaurant

(518) 491-6196

We, the undersigned, request the City of Plattsburgh name the proposed new parking lot Arnold Pavone Square for his service to our community for nearly 70 years.

(16)

HEALEY MANETTE 5498 APT 1 PERU STREET
Name: Address:

Healy Manette
Signature:
Ronald Eastman

KURT & DEBBIE WOODRUFF 187 MARGARET ST.
Plattsburgh

Ronald A. Howard 1 Oswego Ln
Plattsburgh

Ronald A. Howard
Signature:
MELOK

Daniel C. Bonny 599 Calkins Per & NY

Monika Cook 975 Peasleeville Rd 12985

Victoria Mowrey 44 ~~Country~~ LaPointe Rd
Chazy, NY

Victoria Mowrey
Signature:
121 Miller St Plattsburgh N

Paul Seymour
Kendra Seymour } 66 Dudley Rd
Champlain NY

Carrie Plumadore
(Carrie Plumadore) 3429 Silver Lake Rd
Saranac NY 12981

Don Bilow
Jon + Deb Kotraw
Airwaves
Plattsburgh N.Y.
Plattsburgh, NY
Ketcher Lane Plattsburgh NY

Signature:

M. J. C.
LORRAINE STREETER 58 Tom Miller Capaine Street

Petition to City of Plattsburgh

November 30, 2018

Nicholas A. Pope and Jessica Guerin

Arnie's Restaurant

(518) 491-6196

We, the undersigned, request the City of Plattsburgh name the proposed new parking lot Arnold Pavone Square for his service to our community for nearly 70 years.

(78)

Name:

Address:

Signature:

Diane Petrashune
Diane Barber

PO Box 93
Saranac, NY 12981
2952 Rte 374
Ellenburg Dpt NY
12936

Diane Petrashune
Diane L Barber

Patty Wang

PO Box 696
Dunnemoor NY
12929

Sateirick W

Karen Clancy
John Bortolotti

Saranac, NY
Blood Hill Rd
Etowne NY 12932
245 Abner Rd
Morrisonville NY

Karen Clancy
John Bortolotti

Dean Harvey
Mona Pope

64 Champlain

Dean Harvey
Mona Pope

Gina Jarrigue

173 Forest Lane
Morrisonville, NY 12962

Gina Jarrigue

Frank & Lynn McKinney

181 Woodcreek Dr
Spartanburg, SC

Frances Walker
Kim Rule

34 Flynn Ave
Oak St Plattsburgh

Petition to City of Plattsburgh

November 30, 2018

Nicholas A. Pope and Jessica Guerin

Arnie's Restaurant

(518) 491-6196

We, the undersigned, request the City of Plattsburgh name the proposed new parking lot Arnold Pavone Square for his service to our community for nearly 70 years.

18

Name:

Address:

Signature:

Leo (Skip) Muzzy - Pharmacy
Muzzy PO Box 786
Plattsburgh, NY 12929

[Signature]

MARY + BARBARA Maddy 71 COURT ST, Plattsburgh

[Signature]

Leonard + Linda Liberty-Guimond 8 Church St. Keeseville
Guimond NY 12944

[Signature]

Kissy + Michael Ropham 38 W. COURT ST city
12981

[Signature]

KATHLEEN ROSE 1243 RTE 22B MARZESVILLE

LISA LaPorte 191 Dumont Rd West Chazy

[Signature]

Barb Hesert 608 Tom Miller Rd. Plattsburgh, NY

[Signature]

Linda Kowalewski Box 266, Lyon N.Y.

Debbie Bedard 257 CORNELIA ST PLATTS. NY 12901

Jack Moravec 54 Tremblay Ave. Plattsburgh, NY

Mary Ann Brown Dinner was Great - Had a...

Walter Brown

Pell Sherman

Jodie Galarnear 504350 Catherine

Plattsburgh, NY 12901 + 83 Maryland Rd.

[Signature]

Petition to City of Plattsburgh

November 30, 2018

Nicholas A. Pope and Jessica Guerin

Arnie's Restaurant

(518) 491-6196

We, the undersigned, request the City of Plattsburgh name the proposed new parking lot **Arnold Pavone Square** for his service to our community for nearly 70 years.

Name:
Nirita Marshall
Zoe Laughing
Colin Parane

Address:
2092 State Rte 22B
Mamsonville NY 12962
2092 State Rte 22B
mamsonville NY 12962
2092 state Rte 22B
Mamsonville NY 12962
~~Arnold~~

Signature:
Nirita Marshall
2
CP

Meaghan Marlow
37 Ramuzio Rd
Malone, NY 12953

Meaghan Marlow

Seth Marlow (15)

37 Ramuzio Rd.

Malone, NY 12953

~~Seth Marlow~~

Petition to City of Plattsburgh

November 30, 2018

Nicholas A. Pope and Jessica Guerin

Arnie's Restaurant

(518) 491-6196

21

We, the undersigned, request the City of Plattsburgh name the proposed new parking lot Arnold Pavone Square for his service to our community for nearly 70 years.

Name:	Address:	Signature:
NANCI MURRAY	32 PINE RIDGE DR.	Nanci Murray
Erin P. [Signature]	232 Spellman Rd. apt 8.	Erin P. [Signature]
Bryanna Trumble	232 Spellman Rd apt 8	Bryanna Trumble
Linda Carpenter	2399 St. Rt. 3 Cadyville, NY	Linda Carpenter
Roderick Bertrand	2399 Rt 3 Cadyville, NY	Roderick Bertrand
Bonnie Menard	5 Alana Way Platts, NY	Bonnie Menard
Jay Menard	5 Alana Way Platts, NY	Jay Menard
Erin Breyette	Plattsburgh,	Erin Breyette
Karri Breyette	Platt.	K. Breyette
Howard & Maxine Carron		H. Carron
Allan Kesner	133 Prospect Ave	Allan Kesner
Lynette Kesner	133 Prospect Ave	Lynette Kesner

Michelle Gough	812 Bear Swamp Rd Peru Pa	Michelle Ford
Greg Cassidy	814 Bear Swamp Rd Peru	Jim Cow
Terry Cutch	161 Elm Pt. Rd. Addison Vt.	Long Patch
Brenda Cutch	161 Elm Pt Rd Addison Vt	Brenda Cutch
Jim Forcier	1192 STEVENSON RD, WESTPORT	Joe Fran
Sally Rock	4 Durand St Plattsburgh	Sally A Rock
Kathy Livingston	2 University A. Platts	Kathy Livingston
Carolyn St. Clair	18 Copan Ave, City	Carolyn St. Clair
Nancy Gossseau	2952 Route 3 Cadyville NY 12918	Nancy Gossseau
FLOYD - SHIRLEY BORSEY	1160 FT ST.	CHAMBERLYN NY
John S. Carter	130 Margaret St. Northburgh	

Petition to City of Plattsburgh

November 30, 2018

Nicholas A. Pope and Jessica Guerin

Arnie's Restaurant

(518) 491-6196

44

We, the undersigned, request the City of Plattsburgh name the proposed new parking lot **Arnold Pavone Square** for his service to our community for nearly 70 years.

Name:	Address:	Signature:
Elychita Bulard	12 Pine Rdg. Dr	<i>[Signature]</i>
Susan Bouchard	27 Factory Ave Plattsburgh NY	<i>[Signature]</i>
Aneta DuBrey	3 factory Plattsburgh N.Y.	
Marilyn Frotman	12 Joffe Dr Plattsburgh, NY 129	
Byron Bouchard	27 factory Ave. Plattsburgh, NY 1290	
Brandon Bouchard	13 City Hall Plattsburgh, NY 1290	
Mark DuBrey	964 Rt 9 Chazy NY 12924	
Susan Bishop	10 sarara Ave Plattsburgh NY	
Jammi Bell	52 Ruger Brewery Plattsburgh, NY 1290	
Michelle Diman	22 McIntosh Dr Peru, NY 12972	
PAM ROBBINS	49 SANDRA AVE, 12901	<i>[Signature]</i>
Carol Robertson	52 Sandra Ave.	<i>[Signature]</i>
Bobby Hall Jr	14 Crescent Dr.	<i>[Signature]</i>
Jamie A Hall	14 Crescent Dr.	<i>[Signature]</i>
Timothy Colman	5100 Highbridge St Fayetteville, NY	<i>[Signature]</i>
Timothy Colman	28 Grandview Dr.	<i>[Signature]</i>
Cynthia Duffy	Burlington	<i>[Signature]</i>
Dan Loughan	25 Chamber Rd. Plough	<i>[Signature]</i>

Very many good friends 1981

Rawn + Steve Bresso Patricia D. Flattery

Scott DeBuka 39 Sandalwood Platts. NY 12901

Dante McElroy 27 MacDonough St, PO Box 1 Plattsburgh, NY 12901

James P. Haley Luce Latent

Michael and Heather Langlois 9 Mason St. Peru 12972

Al G. Damm

LISABETH & FRITZ KISSNER SS SETH SQ PLATTSBURGH 12901

Mariane & Leonard Priest 530-4 Keddy Hemmingsford Rd

Love We will miss seeing you, we have been here 55 yrs.

Thank you RIP
They didn't make any better
Come Jerry

Neil Calisti 5 Myers

Coral Nedean 19 Bateau Way - Unit 311 Plattsburgh, NY 12903

Leslie R. Hayes 101 Beckman St Plattsburgh, NY 12901

Connie Blondo 443 Tom Miller Rd Plattsburgh

Edie Morelock 606 Lamberton Rd Moores Forks NY 1285

Anna-Rod Skuman 27 Morrison Ave

Sandi Farlotta Just crazy to Red 20

Denise Bauer 9 Deepdale Rd Plattsburgh, NY 12901

Always had a smile! Jimmy - Don't LaPointe

Petition to City of Plattsburgh

November 30, 2018

Nicholas A. Pope and Jessica Guerin

Arnie's Restaurant

(518) 491-6196

We, the undersigned, request the City of Plattsburgh name the proposed new parking lot Arnold Pavone Square for his service to our community for nearly 70 years.

(45)

Name:

Address:

Signature:

Arnie + Beth Pavone

29 Ollivetti Pl. Plattsburgh, NY 12901

Beth Pavone

John & Michelle Collins 12 Lafuze Ln, Peru, NY 12972
Chris & Sharon Dime

Arnie Pavone

Michelle Collins

Lance + Sue Rebideau West Chazy NY

Sue Rebideau

Lance Rebideau

Julian McDonald

24 Collinsway
Plattsburgh NY. 12901

Julian McDonald

Marty + Tina Brothers

8133 RT 22 West Chazy N.Y. 12995

Julia Ryan and Michele Bushey
Patrick Ryan

313 Soper St.
Morrisonville NY

Michele Bushey

Robin + Michele 2116 St Rt 11 Morris NY

Michele Bushey

Shawn + Michele 2116 St Rt 11 Morris NY

Sam & Kerry Adams

21 Fiske Rd. W. Chazy

Kerry Adams

John Patrick Quinn	142 Sunrise dr, Beekmantown, NY	J.P. Quinn
Matthew Quinn	142 Sunrise dr, Beekmantown, NY	Matthew Quinn
Stephen Quinn	142 Sunrise dr, Beekmantown, NY	Stephen Quinn
John Quinn	142 Sunrise dr, Beekmantown, NY	John Quinn
Sue Quinn	142 Sunrise Dr., Beekmantown, NY	Sue Quinn
Gina Garrant	620 Stream Lane, Slingerlands NY	Gina Garrant
Hell. Bond	130 Murgans Trail Sunka Resc. Rec. Fl	Hell. Bond
Vanessa Javant	Blairstown, NJ	Vanessa Javant
Todd Manning	142 Maryland Rd. Plattsburgh, NY	Todd Manning
Joan & Carl Herman	23 Keator Dr. Schenectady, NY 12306	Joan & Carl Herman
John Garrant	8 Holland Ave Plattsburgh, NY 12901	John Garrant
John Garrant	8 Holland Ave Plattsburgh, NY 12901	John Garrant
Ryan Garrant	620 Stream Lane Slingerlands, NY 12159	Ryan Garrant
Lindsey Garrant	8 Holland Ave Plattsburgh, NY 12901	Lindsey Garrant
TRACY ROZELL	83 Sarley AVE PLATS N.Y.	Tracy Rozell
Kristy Rozell	315 CANNING RD SARATOGA	Kristy Rozell

Petition to City of Plattsburgh

November 30, 2018

Nicholas A. Pope and Jessica Guerin

Arnie's Restaurant

(518) 491-6196

We, the undersigned, request the City of Plattsburgh name the proposed new parking lot **Arnold Pavone Square** for his service to our community for nearly 70 years.

⑧

Name:	Address:	Signature:
Sandra Briggs	Cumberland Ctr	Janet M. Briggs
Chris Baker	5032 S. Catherine St.	Chris Baker
Liz Boirier	Apt. A-	Liz Boirier
Ben Holmes	70 B Waterhouse St.	Ben Holmes
Jenna Pavone	1971 St. Rte 22B	Jenna Pavone
Marc Pavone	1 Bruce St. Apt 2 Scotia NY 12302	Marc Pavone
Jessica Peck	105 SERENITY DR RUBY NY 12475	Jessica Peck
Stephanie Rabideau	15 Palmer Street Apt B. Plattsburgh NY 12901	Stephanie Rabideau
Mary Rabideau	22 Wheeling Ave. Plattsburgh NY 12901	M. Rabideau
Brian F. Rabideau	84 Firehouse Lane Platts	Brian F. Rabideau
Kenn Donoghue	24 Firehouse Platts	Kenn Donoghue
Brittani Pavone	260 Rye Brook Platts	Brittani Pavone
Ben Pavone	220 Newark Ave. Jersey City NJ 07302	Ben Pavone
Judy Pavone	220 Newark Ave #1 Jersey City, NJ 07302	Judy Pavone
Nicole Pavone	1327 Route 5 Morrisville NY 12962	Nicole Pavone
Collin Granaroli	830 Robin Dr. #1 Incline Village, NV	Collin Granaroli
	830 Robin Dr. #1 Incline Village, NV	Collin Granaroli

Alice Heckard
Richard T. Heckard

18

60 Club Rd, Unit 101
Plattsburgh, NY 12903
40 Club Rd unit 101
Plattsburgh, NY 12903

Alice Heckard
Richard T. Heckard

Petition to City of Plattsburgh

November 30, 2018

Nicholas A. Pope and Jessica Guerin

Arnie's Restaurant

(518) 491-6196

We, the undersigned, request the City of Plattsburgh name the proposed new parking lot Arnold Pavone Square for his service to our community for nearly 70 years.

17

Name:

Address:

Signature:

Jennifer Madore
Leigh Tyler

P.O. Box 410 Peru, NY 12972
18 Alana Way Plattsburgh NY

[Signature]
Leigh Tyler

Dan Stockdale
Magen VanderWeer

16 Chenango Rd. Platts.
80 Scully Ave. Apt. 202 Platts. NY
56 Mannix Rd, Peru, NY 12972
John R. Lacey 11 Pleasant

Dan Stockdale
Magen VanderWeer
[Signature]

Brian Lamoy
Ben Hally
Debbie Lenney

11 Pleasant St Plattsburgh
Debbie Lenney

Paul ALBERT Stielor

PO BOX 31
ROUSES PT.
N.Y. 12979

[Signature]
P.A. Stielor

Ben Batterson
Bart Fuller

275 Allen Rd, Platts.
7 Oak, Plattsburgh

[Signature]
Ben Batterson

Jody Bender
Tracy Bradley

461 Roseac Rd Etown

[Signature]
Jody Bender

Shane Murphy
Rosa Caruso

71 Haynes Rd, Plattsburgh
5366 Peru St. Plattsburgh
SALLEY AVE

Wm H. Brad
Shane P. Murphy
[Signature]

Name	Address	Signature
Denise Durkin	4 Flaglar Dr. Plattsburgh	Denise Durkin
Charles Durkin	41 Flaglar Dr. Plattsburgh	Charles Durkin
Mathieu Durkin	4 Flaglar Dr. Plattsburgh	Mathieu Durkin

(17)

Petition to City of Plattsburgh

November 30, 2018

Nicholas A. Pope and Jessica Guerin

Arnie's Restaurant

(518) 491-6196

We, the undersigned, request the City of Plattsburgh name the proposed new parking lot Arnold Pavone Square for his service to our community for nearly 70 years.

18

Name:

Address:

Signature:

Wm Dashnaw
Thomas P. Patterson
Don + Kathy Bruce

POB 2, Park
275 Ader Road
Plattsburgh NY
24 Henry St Drive
Pom NY 12972

Wanda A. Johnson
Theresa Kottler
Kathryn Brun
Carol Brun

Jean Rascoe

66 Diceson Pl Rd
Stafford Rd Plattsburgh NY

Jean Rascoe

Albert Rascoe

STAFFORD RD PLATTSBURGH, NY

Michelle Rascoe

Suzette Pavo

32 Olivetti Place, Platts. NY

Suzette Pavo

RICHARD PAVONE

32 OLIVETTI PL. PLATTSBURGH NY

Richard Pavo

Blake + Françoise

57 Melody Lane Platts NY

Blake + Françoise

Larry + May LaValley
Matthew Chase

22 Erin Ave., Plattsburgh, NY 12901
28 Lexington Ave. Plattsburgh NY 12901

Larry + May LaValley
Matthew Chase

JEFF CHASE

12 Phillips Ct. Lyon Mtn. NY 12952
12 PHILLIPS CT LYON Mtn NY 12952

Jeff Chase

JACKIE O'Hare
Tedi Bourg

942 State Rte 3 PLB, NY 12901
52 Tiffany Way Plattsburgh 12901

Jackie O'Hare
Tedi Bourg

Kris. Elsenheimer

897 Standish Rd Saranac NY 12901

Kris. Elsenheimer

Randy Larkin	167 Cornelia St	Randall R Larkin
Karen Larkin	11	Karen A Larkin
LAWRENCE K. SHANLEY	24 School St	Lawrence K. Shanley
MARCIA M. SHANLEY	24 School St.	Marcia Shanley
EDWARD S. REYNOLDS	26 LORRAINE ST.	Edward Reynolds

(21)

Petition to City of Plattsburgh

November 30, 2018

Nicholas A. Pope and Jessica Guerin

Arnie's Restaurant

(518) 491-6196

We, the undersigned, request the City of Plattsburgh name the proposed new parking lot **Arnold Pavone Square** for his service to our community for nearly 70 years.

29

Name:

JOHN DONOGHUE

Address:

2 BRODERICK RD
PLATTSBURGH NY
12901

Signature:



Karen Donoghue

2 Broderick Rd
Plattsburgh NY 12901

Karen Donoghue

Jennifer Donoghue

260 River Rd.
Peru NY 12972

Jennifer

Betty Donoghue

23 Bruce Dr
Peru, N.Y. 12972

Betty Donoghue

Penny Converse

93 Brinkerhoff St

Plattsburgh

Terry Donoghue

171 Bugar St.
PLATTSBURGH NY 12901

Terry Donoghue

CHAD ERICKSON

60FF AVE

Nicole Blanchard

PLATTSBURGH NY
122 A Sharron Ave. NY

Nicole Blanchard

Melody Bushey

Nisa, Andy Hastings

2404 Watersglenn Drive

Jenny and Mark Duckworth - Blaha Apex, NC Jenny Duckworth

Patrick & Kelly McCann

52 Old Dock Rd
Plattsburgh
Kelly McCann

Rick Idarney
3 generations of family
comes here.

227 Dawn Rd
Peru NY 12970
Rick

Richard & Jan Ambrose
Susan Scott

16th Loan Place
Plattsburgh NY
2167 Way Pt.
Plattsburgh, NY 12901

Rhoda & Charlie Scott
346 Cemetery Rd.
Plattsburgh, N.Y. 12901

Francesca Campa
29 River Side Ave
Plattsburgh NY

Lisa Campa
29 River Side Ave
Plattsburgh NY

Cody Rowbottom

Alex Campa

Megan Buddell
32A Montcalm Ave
Plattsburgh, NY 12901

Gary O. Duquette Jr.

32 Montcalm Ave
Platts. NY

Kelly A. Dodson
1979 Longmont Dr.
Wake Forest, NC 27587

Michael Marwan
8 Holland Ave.
Plattsburgh, NY

Nancy Ines
7133 Warren Rd
Ithaca, NY

Kath Carvill
8 Holland Ave.
Plattsburgh,
NY
12901

